

*A.V.W. EQUIPMENT*

*Pivoting Oscillating High  
Pressure Arch Electric*

*Model  
PO1-EL*



# PIVOTING OSCILLATING HIGH PRESSURE ARCH, MODEL PO1-EL

*The AVW Stainless Steel Pivoting Oscillating High Pressure Arch produces an even spray of up to 1000 Psi over the entire vehicle. Pivoting Top blasts the front, top and rear of vehicles, while the pivoting Side blasters cover both sides, tires and rockers areas.*

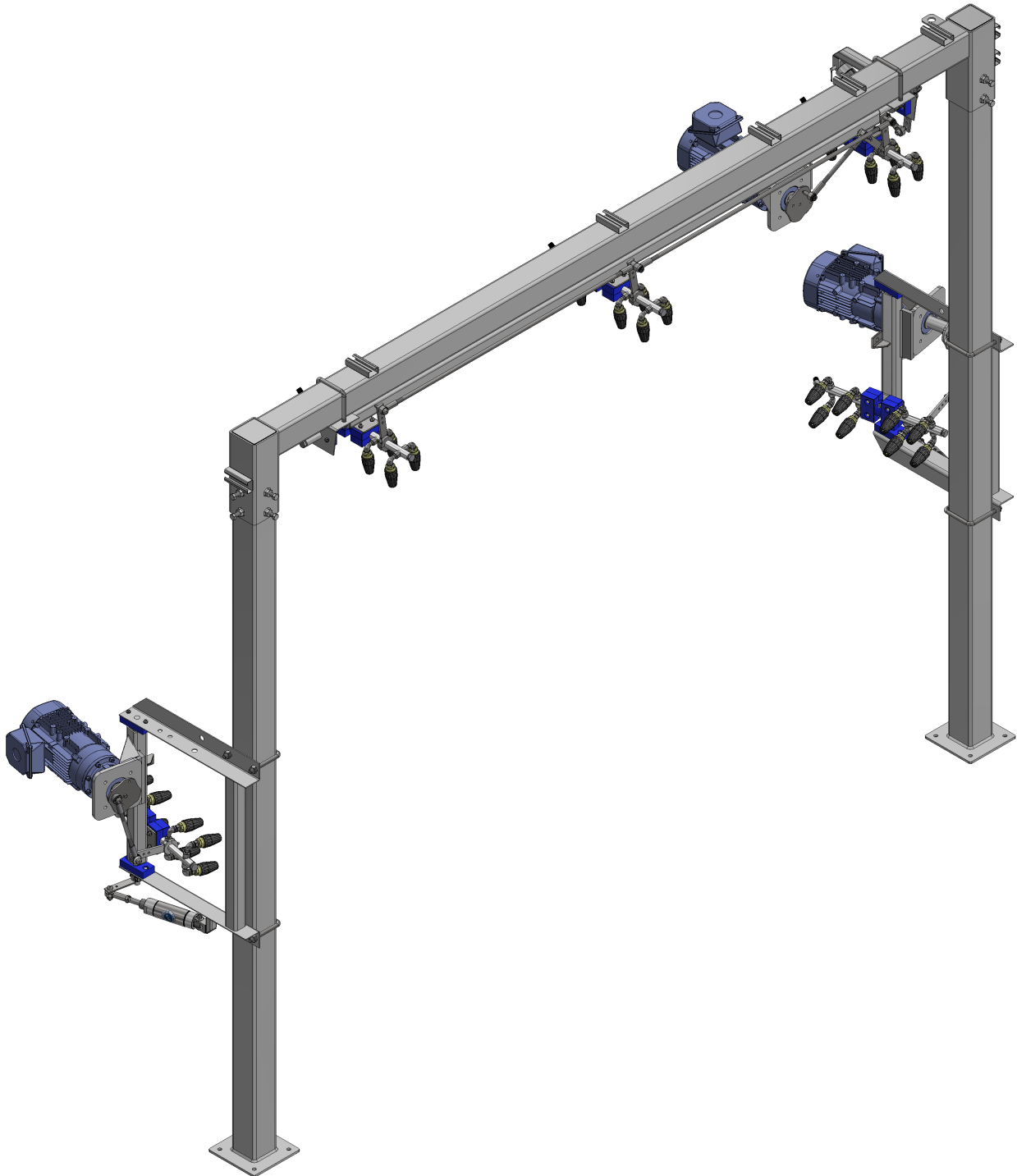

# PIVOTING OSCILLATING HIGH PRESSURE ARCH, MODEL PO1-EL

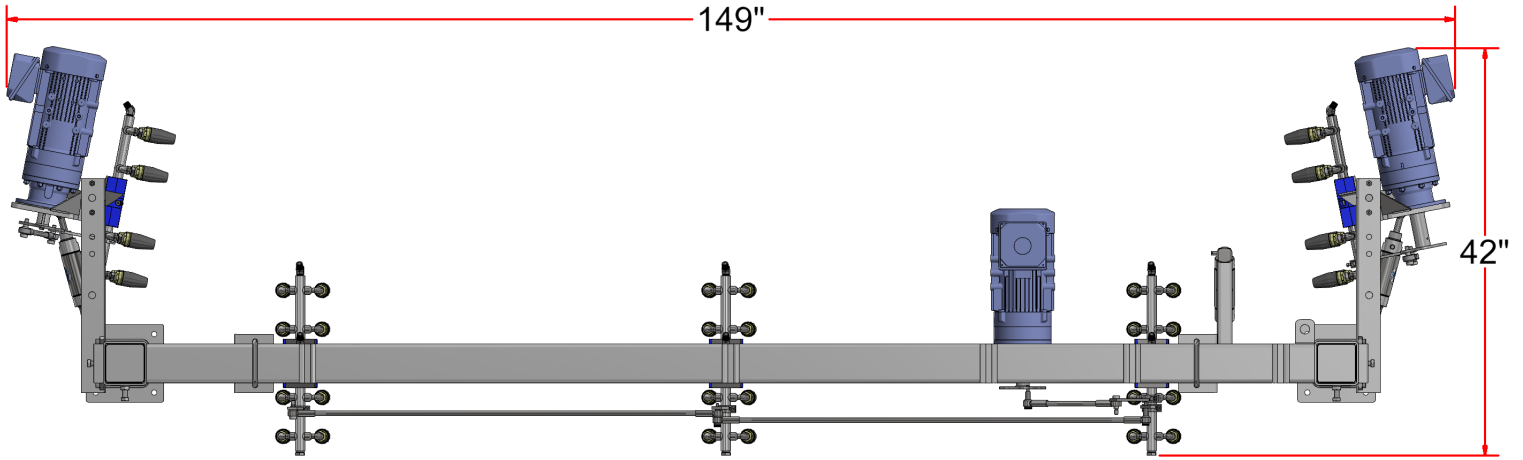

## *SPACE REQUIREMENT*

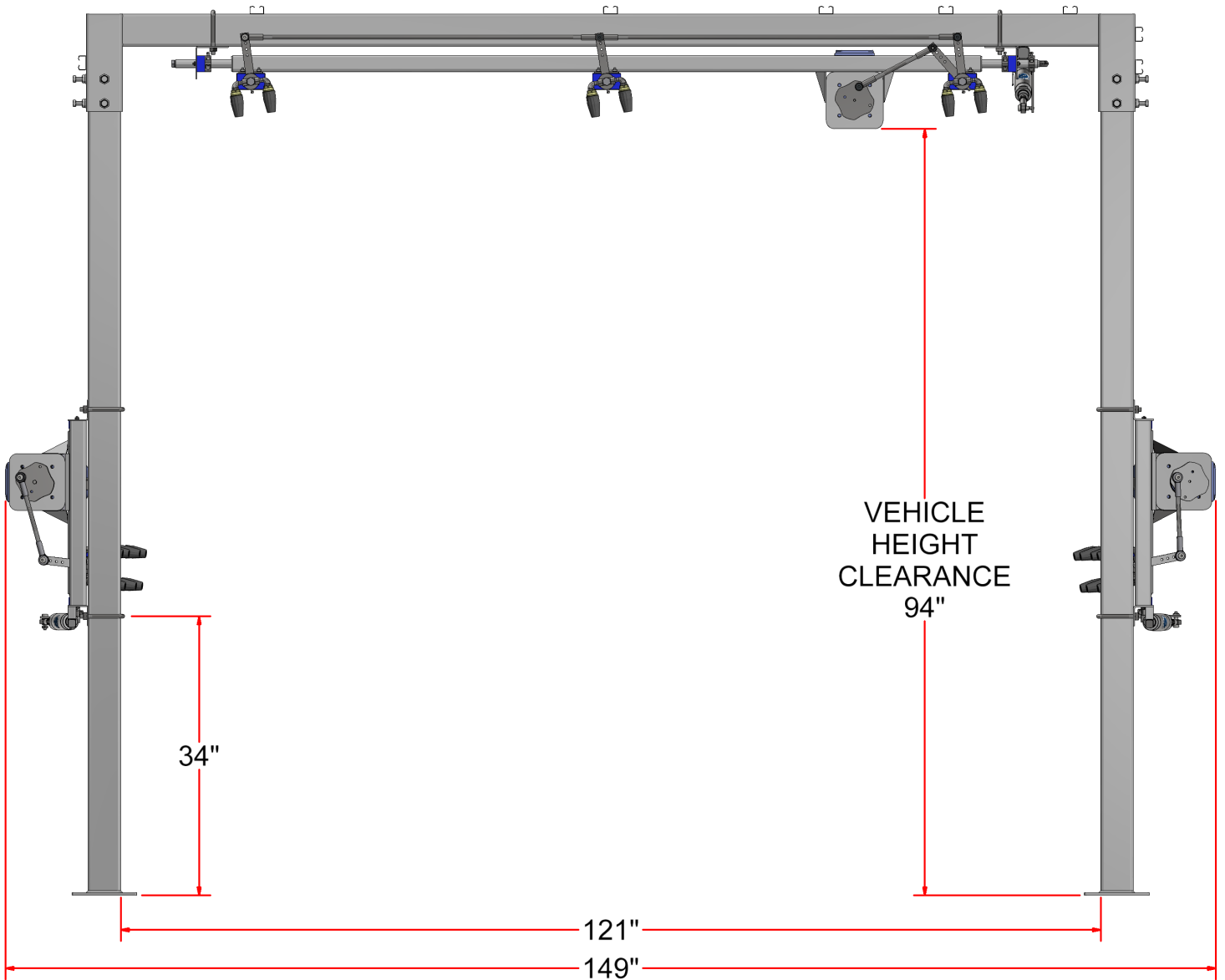

# PIVOTING OSCILLATING HIGH PRESSURE ARCH, MODEL PO1-EL

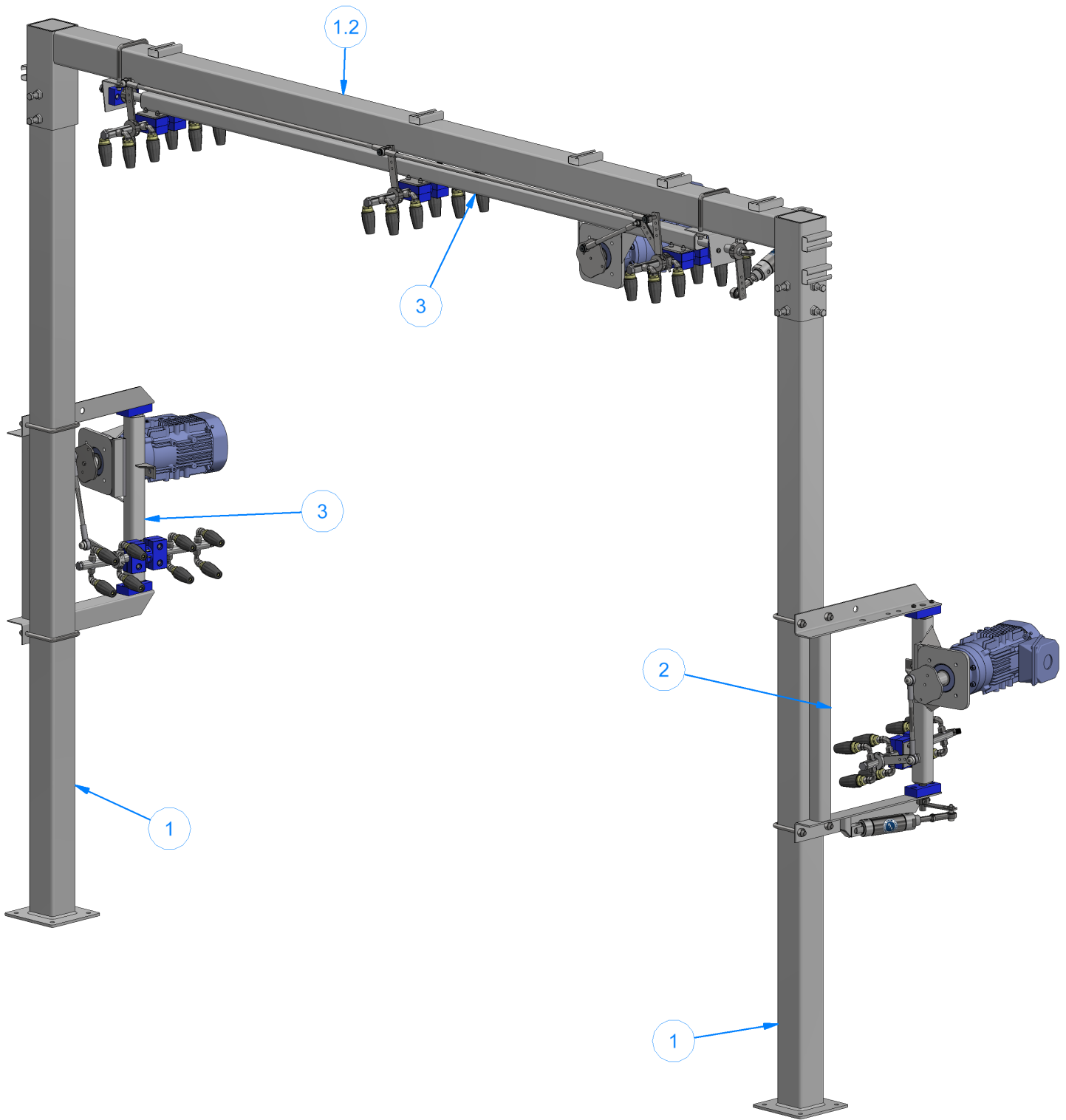

# PIVOTING OSCILLATING HIGH PRESSURE ARCH, MODEL PO1-EL

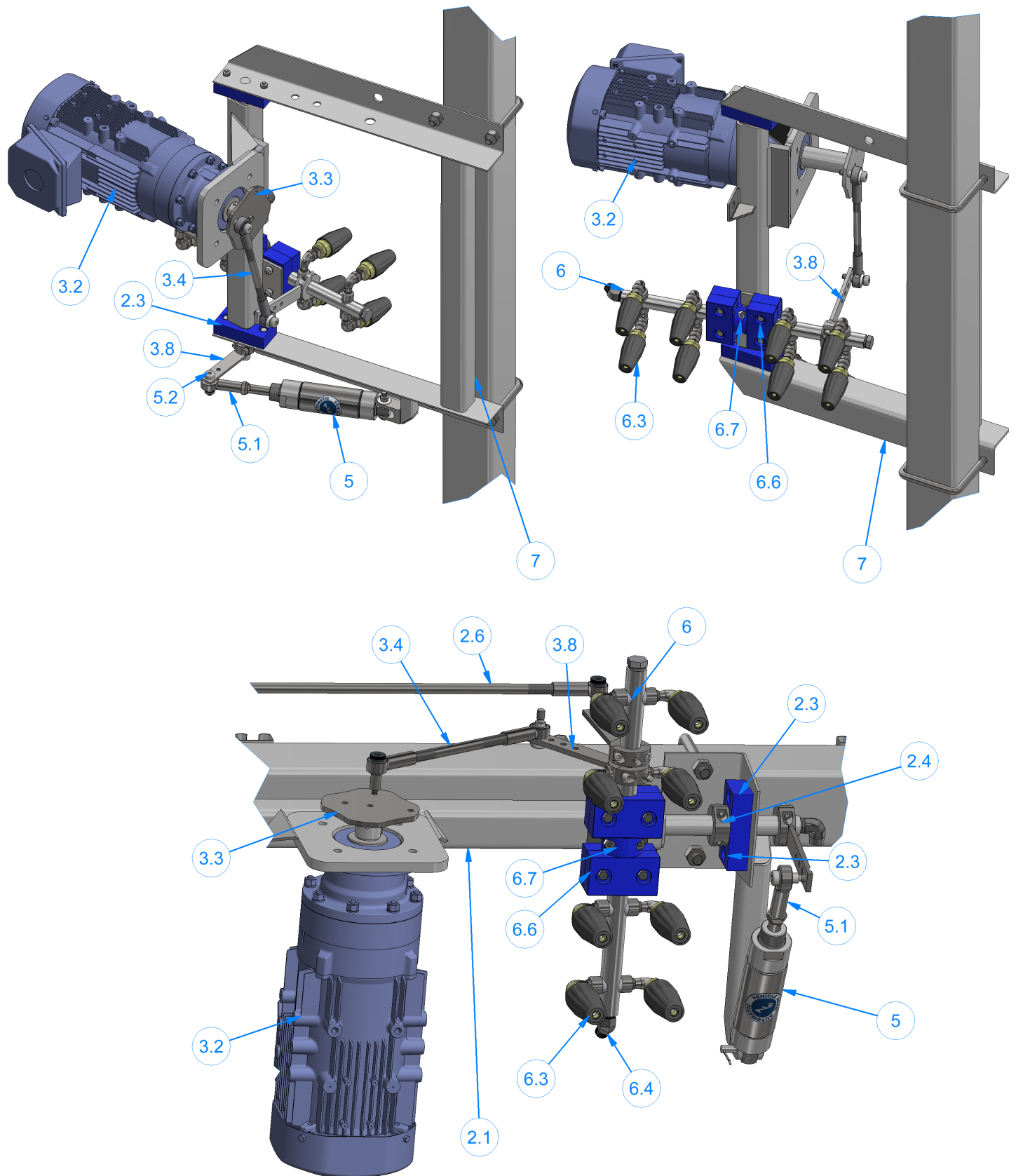

# PIVOTING OSCILLATING HIGH PRESSURE ARCH, MODEL PO1-EL

ITEM	Description	PART No.	QTY
1 1.2 - - -	LEG <b>HOLDING TOP BAR</b> -w/SQ.U BOLTS 3/8" SIZE and -FLAT WASHERS 3/8" and -HEX NUTS 3/8"	PO1A PO1B UB-SQ0375x1400 FW380875 HN3816	2 1 2 4 4
2 2.1 2.2 2.3 2.4  2.5 2.6 2.7	<b>PIVOTING BAR ASSEMBLY</b> PIVOT BAR 92"LG MOTOR MOUNT WELDED TO PIVOT UHMW PIVOT BLOCK 1" I.D. UHMW SINGLE SPLIT COLLAR 1" I.D. -NYLON LOCK NUT -HEX HEAD CAP SCREW PIVOTING BAR MOUNTING BRACKET OSCILLATING ARM ASSEMBLY ROD THREADED ENDS1/2"x41"Lg	- PO1CH PO1CHA - PO1C1 MC1DDA NLN1213 HHCS1420150 -	1 1 1 2 2 2 2 1
3 3.1 3.2 3.3 - 3.4 3.5 3.6 - 3.7 - - 3.8	<b>PIVOT DRIVE ASSEMBLY</b> MOTOR MOUNT ELECTRIC MOTOR OSCILLATING DISK w/HEX NUTS 1/4" OSCILLATING ARM ASSEMBLY BALL JOINT ROD END1/2-20 ROD THREADED ENDS1/2"x10"Lg HEX NUT 1/2" SHOULDER BOLT 1/2" w/FLAT WASHER NYLON LOCK NUT CAM	- RT1AAC GRMTR1-5HP-81-230-460 SB2ADBA HN1420 PO1CBB-10 BJ1-2-20 PO1CBB1-10 HN1213 SB1ADB1 FW38 NLN1213 PO1-CAM2	2 2 3 3 - 3 6 2 1 2 1 2 5
4 4.1	<b>PIVOT OSCILLATING TOP MANIFOLD ASSEMBLY:</b> CYLINDER MOUNTING BRACKET [for Top Manifold]	PO1C PO1CB	1 1
5 5.1 - 5.2 - 5.3 5.4	CYLINDER BALL JOINT ROD END 1/2" -20 JAM NUT SHOULDER BOLT 1/2" HEX NUT 1/2" COLLAR PIN	AC2x3 BJ1-2-20 JN1220 SB1ADB1 HN1216 TB1AEA	3 3 3 3 3 3
6 6.1 6.2 6.3 6.4 - 6.6 - - 6.7 - -	<b>MANIFOLD ASSEMBLY</b> WATER MANIFOLD 90°STREET ELBOW 1/4"x1/4", (8/PER MANIFOLD) NOZZLE 1/4" MEG 0504, (8/PER MANIFOLD) ELBOW- 1/2JICx1, (1/PER MANIFOLD) PLUG 1/2", (1/PER MANIFOLD) UHMW-BLOCK SET (2 SETS/PER MANIFOLD) -NYLON LOCK NUT -BOLT UHMW SPLIT COLLAR 1" I.D. (1/PER MANIFOLD) -NYLON LOCK NUT -BOLT	PO1DM PO1DMA EL90-S-304025 1-4MEG-0504 - PLUGPP050 PO1C2 NLN1213 HHCS1420200 RT1DDA NLN1213 HHCS1420150	1 3 24 24 3 5 10 12 12 5 3 3
7 - - - -	<b>PIVOTING SIDE OSCILLATOR [DRIVER/PASSENGER]</b> SIDE MANIFOLD—FRAME SQ. U BOLTS 3/8" SIZE FLAT WASHER 3/8" HEX NUTS 3/8	PO1D/PO1E - UB-SQ0375X1400 FW38 HN3820	1/1 - 4 8 8

