

DUAL Z-WRAP w/DUAL MINI MITTER COMBO, Model 2WDM5

The Stainless Steel AVW - Z - Dual Wrap w/Dual Mini Mitter Combo and the best Mini Mitter combined in one unit ideal for space savings in tunnels and clean appearance desired in longer tunnels.

Z-Wrap Around operate gravity. No complicated controls, because of the Design it can self adjust to most conveyor speed requirements.

Simple design is constructed of heavy grade Stainless steel designed to rotate reverse of the AVW Wrap Around and to provide constant pressure to the side of vehicles. Van High brush height is ideal for vans and sport utility vehicles because it cleans the sides with smooth even pressure.

*Compact cleaning (12')
Retract kit is available*

*For Wrap Around:
Displacement 12.05cu.in./rev.,
18GPM, 60 RPM)
Water:
1/2" NPT Outlet
Equipment Center Line*

*For Mini Mitter:
3.6GPM, 60RPM
Water:
1/2" NPT, 3GPM*

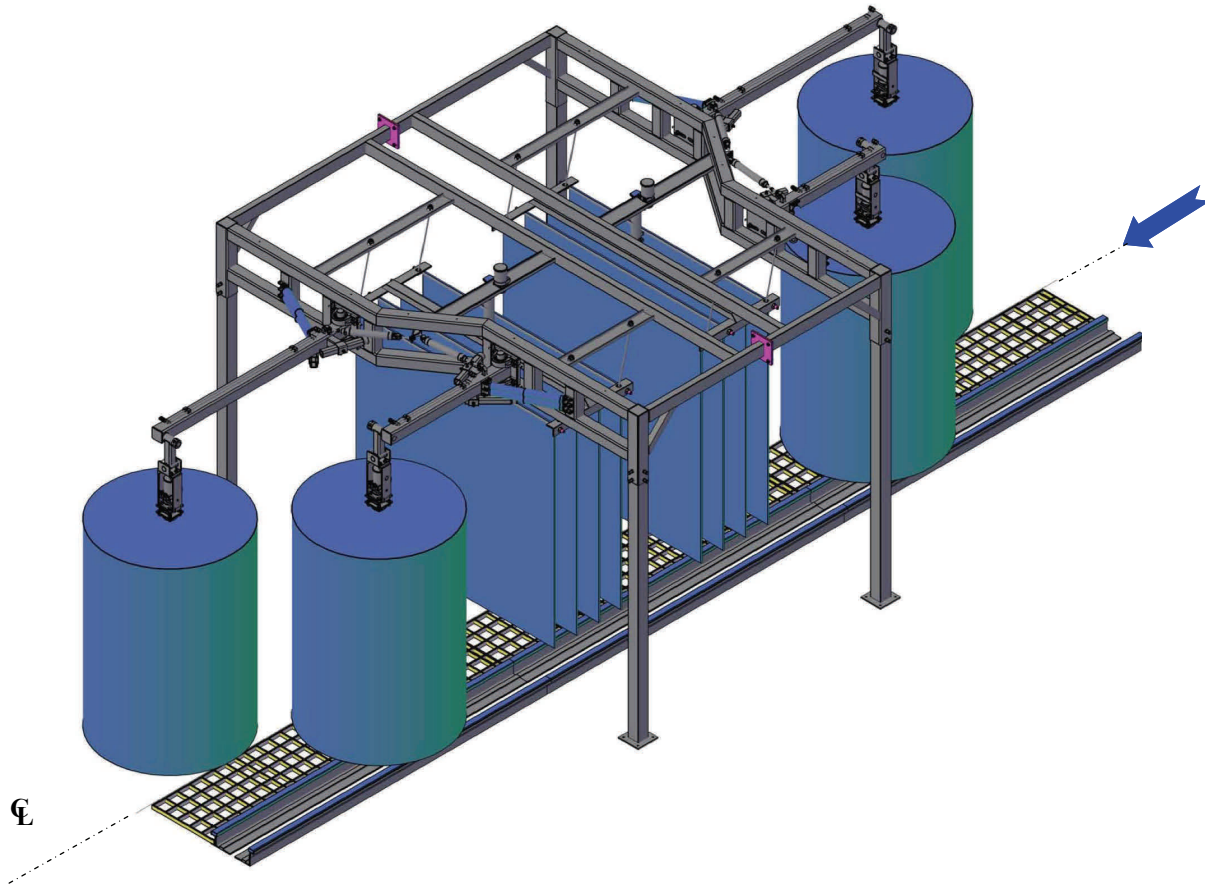

DUAL Z-WRAP w/DUAL MINI MITTER COMBO, Model 2WDM5

SPACE REQUIREMENT

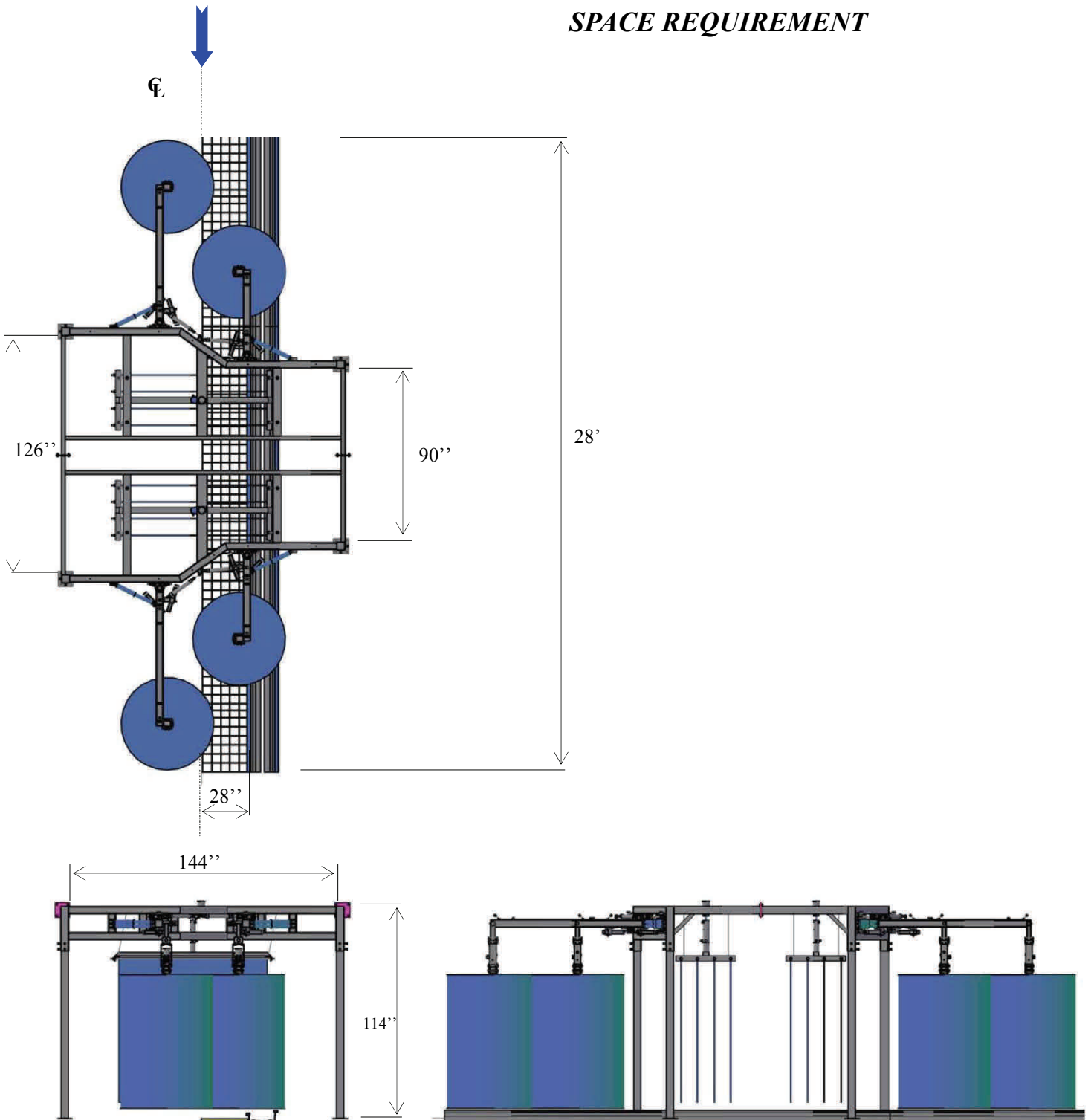

DUAL Z-WRAP w/DUAL MINI MITTER COMBO, Model 2WDM5

PARTS:

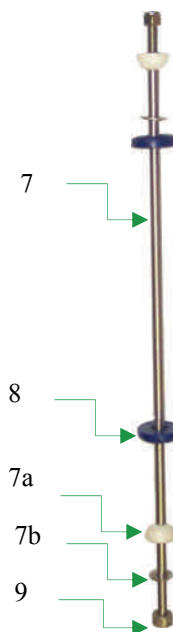
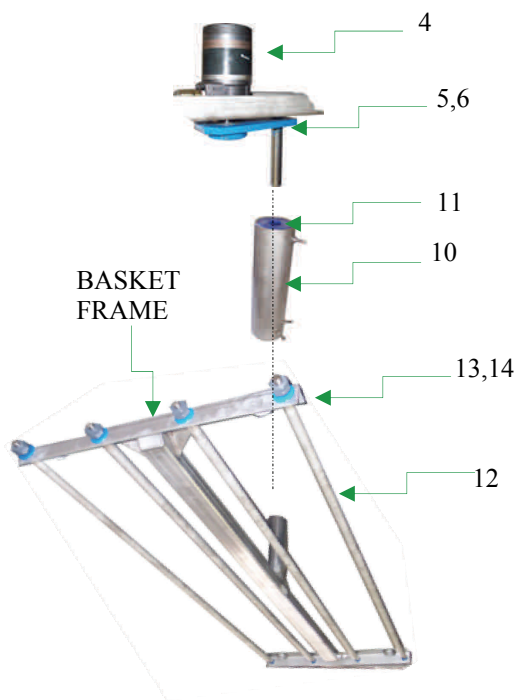
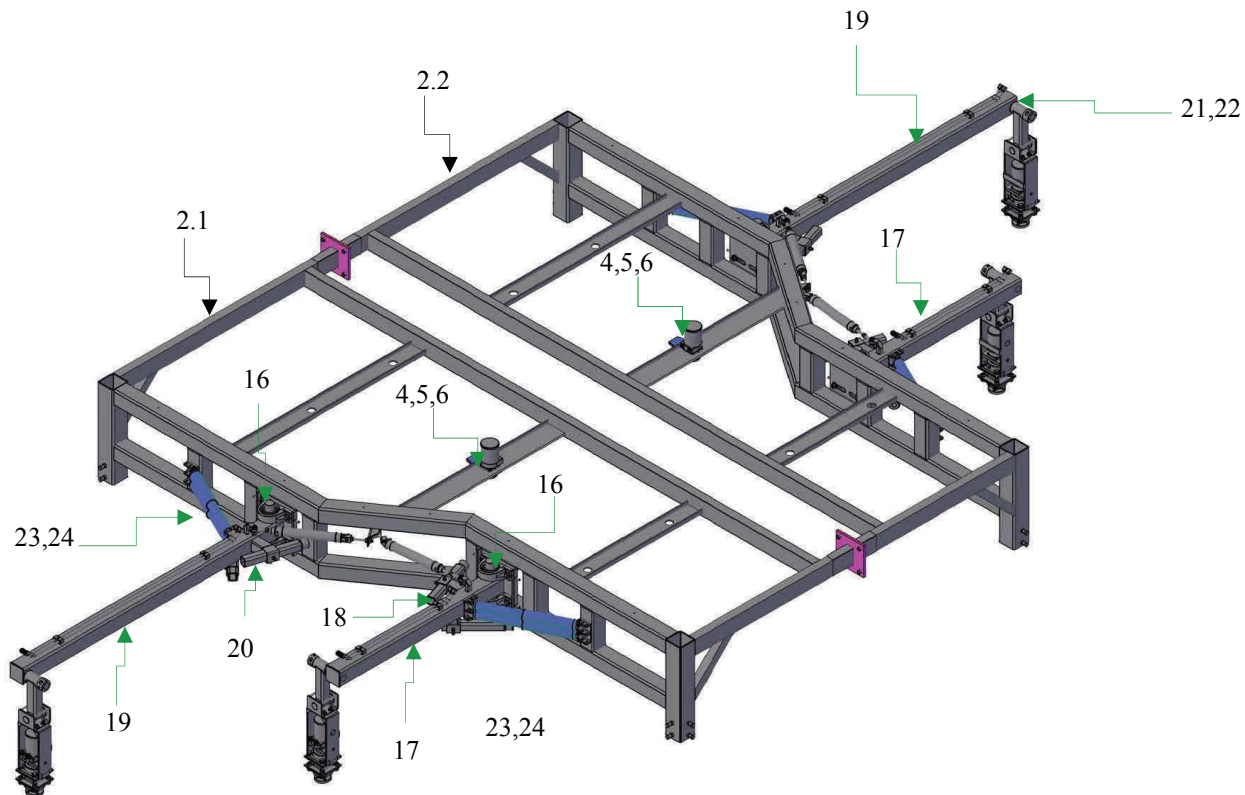

4. HYDRAULIC MOTOR



5,6. CAM ARM and SPLIT TAPER BUSHING



DUAL Z-WRAP w/DUAL MINI MITTER COMBO, Model 2WDM5

WRAP AROUND-PARTS

1.LEG



PVDE NOZZLE 1/4"
08E40



16. PILLOW
BLOCK

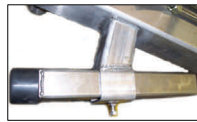

18. RUBBER STOP ASSEMBLY

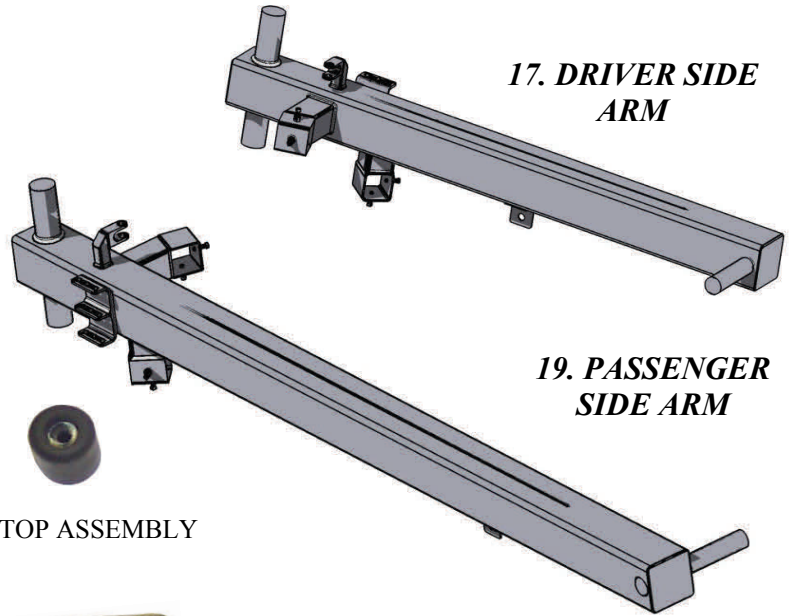

17. DRIVER SIDE
ARM

19. PASSENGER
SIDE ARM

26. MOTOR
MOUNT

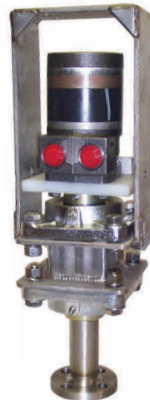

HYDRAULIC
MOTOR

BRUSH
SHAFT



Torque
plate

25 UNIVERSAL
COUPLING

25.A FLEX
COUPLING
(optional)

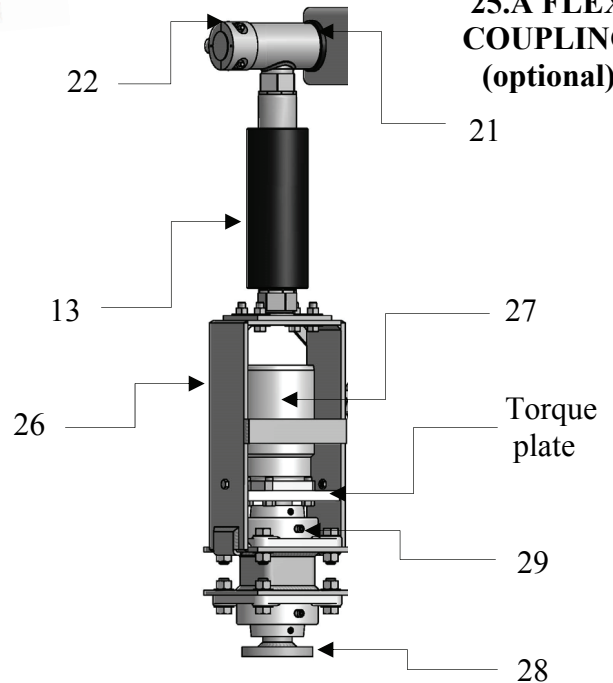
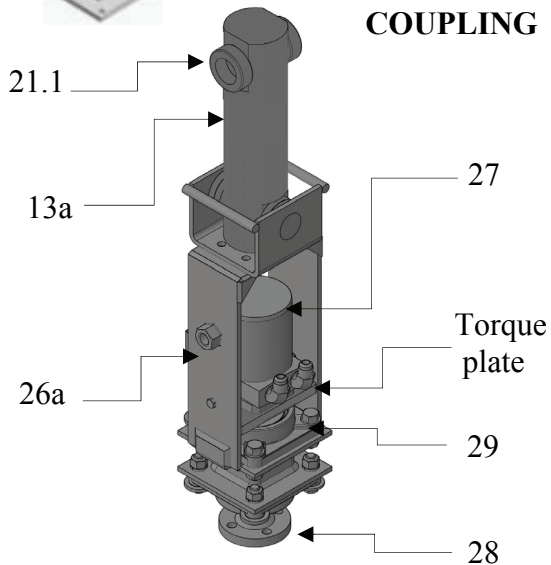

MOTOR MOUNT ASSEMBLY



DUAL Z-WRAP w/DUAL MINI MITTER COMBO, Model 2WDM5

WRAP-PARTS

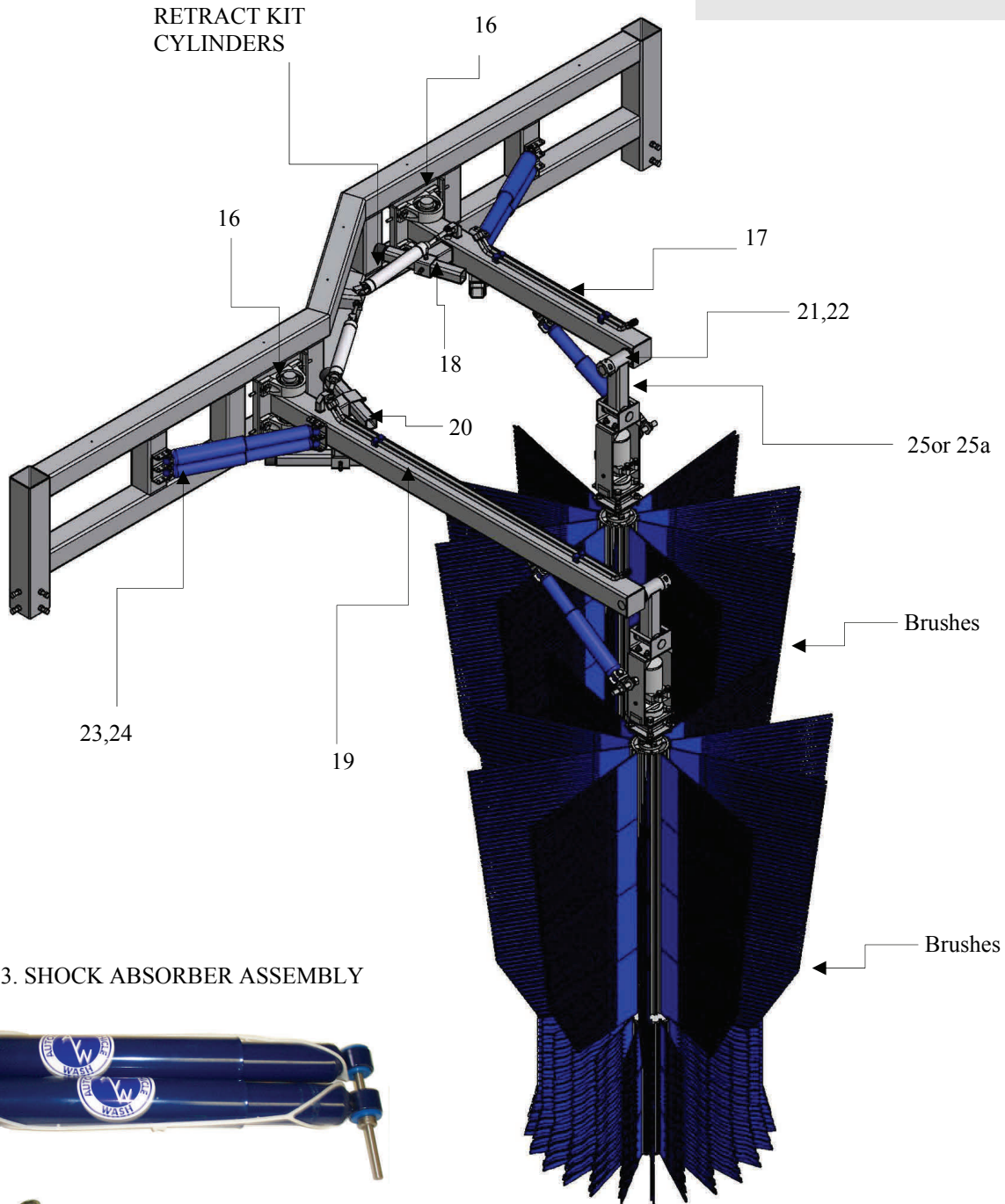

23. SHOCK ABSORBER ASSEMBLY



24. PIN, COLLAR



DUAL Z-WRAP w/DUAL MINI MITTER COMBO, Model 2WDM5

ITEM	Description	PART No.	QTY.
1	LEGS	WC3A	4
2	FRAME ASSEMBLY	2WDM5AB	1
2.1	FRAME 1	2WC3BA-1	1
2.2	FRAME 2	2WC3BA-2	1
-	Square Head Screw 1/2"-13x1-1/2"lg(for Sleeves)	SQHS1213150	16
-	Hex Head Cap Screw 3/8"-16x2"lg (fully threaded, for pillow block adjustment)	HHCS3816200F	8
4	BASKET DRIVE ASSEMBLY: Hydraulic Motor, displacement 11.9 [cu.in./rev.]	MC2BB-1104 WA1KM	2 2
-	Fitting Straight 1/2" NPTM x 1/2" JIC	SAE070102-8-8	4
5	Cam Arm w/welded weld-on hub	MC2BBA-P1-0615	2
6	Split Taper Bushing P1 1"	STB-P1X100	2
-	Hex Head Cap Screw 3/8"-16x 3/4" LG. (motor's fastener)	HHCS3816075	8
-	BASKET SUPPORT ROD ASSEMBLY:	MC1C	8
7	Basket support Rod 1/2" x 27" LG.	MC1C1	8
8	Basket support Disk UHMW	MC1C2	16
7a	Basket support Halfball	MC1C3	16
7b	Flat Washer 1/2" I.D.x1 1/4" O.D.	FW12125	16
9	Nylon Lock Nut 1/2"-13	NLN1213	16
-	BASKET ASSEMBLY	MC2D	2
-	Basket Frame 7"	MC2DA	2
-	Sleeve Assembly:	MC1DB	2
10	Sleeve	MC1DB1	2
11	UHMW Bushing 1" I.D.	MC1DB2	2
-	Square Head Screw 3/8"-16x 3/4" LG.	SQHS3816075	6
-	Hex Nut 3/8"-16	HN3816	6
-	CURTAIN ROD ASSEMBLY:	MC2DC	8
12	Curtain Rod 88" LG.	MC2DCA	8
13	Plastic Spacer 1" I.D.x2" O.D.x 1/4" width	MC1DC2	16
14	Plastic Spacer 7/8" I.D.x1 1/2" O.D.x3/16" width	MC1DC1	16
-	Plastic Hex Nut 3/4"-10	PLHN3410	32
15	CURTAIN (CLOTH)	MC1E	72



DUAL Z-WRAP w/DUAL MINI MITTER COMBO, Model 2WDM5

ITEM	Description	PART No.	QTY.
16	PILLOW BLOCK 2"	WA1WB	8
-	Screw Fastener Set (for Pillow Block):	-	16
-	Hex Head Cap Screw 1/2"-13x2-1/4"lg	HHCS1213225	16
-	Flat Washer 1/2" I.D.x1-1/4" O.D	FW12125	32
-	Split Lock Washer 1/2"	SLW1/2	16
-	Hex Nut 1/2"-13	HN1213	16
-	DRIVER SIDE ARM ASSEMBLY	WA1D	2
17	DRIVER SIDE ARM 46" Lg	WA1DA	2
18	RUBBER STOP ARM ASSEMBLY	WA1DB	4
-	STOP ARM	WA1DBA	4
-	RUBBER BUMPER	WA1DBB	4
-	SCREW FASTENER SET 3/8"	-	4
-	HEX HEAD CAP SCREW 3/8"-16x1-1/4"lg	HHCS3816125	4
-	FLAT WASHER 3/8" I.D x 7/8" O.D	FW38087	4
-	HEX NUT 3/8"-16	HN3816	4
-	Square Head Screw 1/2"-13x1-1/2"lg(for STOP Adjustment)	SQHS3816075	8
-	PASSENGER SIDE ARM ASSEMBLY	WA1E	2
19	PASSENGER SIDE ARM 76" Lg	WA1EA	2
-	BRACKET for RETRACT KIT (Welded to Arm)	WA1DAD	2
20	RUBBER STOP ARM ASSEMBLY	WA1DB	4
-	STOP ARM	WA1DBA	4
-	RUBBER BUMPER	WA1DBB	4
-	SCREW FASTENER SET 3/8"	-	4
-	HEX HEAD CAP SCREW 3/8"-16x1-1/4"lg	HHCS3816125	4
-	FLAT WASHER 3/8" I.D x 7/8" O.D	FW38087	4
-	HEX NUT 3/8"-16	HN3816	4
-	Square Head Screw 1/2"-13x1-1/2"lg(for STOP Adjustment)	SQHS3816075	8
21	PLASTIC SPACER (for FLEX COUPLING)	WA11	4
21.1	PLASTIC SPACER (for UNIVERSAL COUPLING)	WA11-0112	4
22	2-PIECE COLLAR 1-1/2"	WA2J-2P	4



DUAL Z-WRAP w/DUAL MINI MITTER COMBO, Model 2WDM5

ITEM	Description	PART No.	QTY.
23	SHOCK ABSORBER ASSEMBLY	WA1FA	4
	- SHOCK ABSORBER	WA1FAA	4
	- UHMW BUSHING 3/8" I.D.	WA1FA1	8
24	PIN Ø 3/8" x 6" LG	WA1FB	8
	- COLLAR 3/8"	WA1FC	8
25	UNIVERSAL COUPLING ASSEMBLY (Optional)	WA2H-0112	4
	- UHMW Flex Coupling	WA2HA-0112	4
	- UHMW Bushing 1 1/2" I.D.	WA1H2	4
	- Mounting Channel	WA2HC	4
	- Shaft 1 1/2" x 6 1/4" Lg	WA2HD	4
	- Collar 1 1/2" I.D. x 2 1/2" O.D. x 7/8" width	WA1J	8
25a	FLEX COUPLING (optional)	WA1H	4
	- Welded Flex Coupling	WA1HA	4
	- Wrap CAM	WA1HB	4
	- UHMW Sleeve	WA1H1	4
	- UHMW Bushing 1-1/2" I.D.	WA1H2	4
	- SCREW FASTENER SET 3/8"	-	16
	(Connection of the Flex coupling with motor Mount)		
	- HEX HEAD CAP SCREW 3/8"-16x3/4"lg	HHCS3816075	16
	- FLAT WASHER 3/8" I.D x 7/8"O.D	FW38087	16
	- HEX NUT 3/8"-16	HN3816	16
26	WRAP AROUND SHAFT ASSEMBLY	WA5K	4
	- MOTOR MOUNT	WA5KA	4
	- Motor Retaining Screw:	-	8
	- Hex Head Cap Screw 3/8"-16 x 3/4" lg.	HHCS3816075	8
	- Nylon Lock Nut 3/8"-16	NLN3816	8
27	HYDRAULIC MOTOR, displacement 11.9 [cu. in./rev.]	WA1KM	4
	TC0195FP100AAAB	SAE070202-8-8	8
	-FITTING 90° Elbow 1/2" NPTM x 1/2" JIC	WA1K1	4
	- TORQUE PLATE	HHCS3816075	16
	- Hex Head Cap Screw 3/8"-16 x 3/4" lg. (motor's fastener)	WA5KB	4
28	BRUSH SHAFT Ø 1 1/2" x 10 1/2" lg.	WA1KCB	8
29	4-BOLT BEARING 1 1/2"	-	32
	- Screw Fastener Set (for bearing):		
	- Hex Head Cap Screw 1/2"-13x1 3/4"lg.	HHCS1213175	32
	- Flat Washer 1/2" I.D. x 1" O.D.	FW12100	32
	- Split Lock Washer 1/2"	SLW12	32
	- Hex Nut 1/2"-13	HN1213	32



DUAL Z-WRAP w/DUAL MINI MITTER COMBO, Model 2WDM5

ITEM	Description	PART No.	QTY.
30	BRUSH ASSEMBLY (design: 5" core, 72"lg.) SCREW FASTENER SETS 1/2"-13x1 1/2"LG.: -Hex Head Cap Screws 1/2"-13x1 1/2"LG.. -Flat Washers 1/2" I.D.x1 1/4" O.D. -Split Lock Washers 1/2" -Hex Nuts 1/2"-13	WA1M-5/10X72	4
31	HYDRAULIC & WATER INSTALLATION: ----- Side Water Manifold Assembly (on exit legs): Manifold Hollow Hex Plug 1/2" NPTM Barb 1/2" x 1/2" NPTM Nozzle 1/4" NP Water Hose 1/2" I.D. (braided reinforced polyethane tubing) Female Pipe Tee 1/2" NPTF Barb 1/2" x 1/2" NPTM ----- Pipe clamp 3/4", for water hose and side water manifolds (w/screw fasteners 1/4") ----- Top water manifold assembly: Top water manifold (tubing 1" O.D. x 34"lg. w/4 water outlets, 10" apart one from another) Hollow hex plug 1/2" NPTM Barb 1/2" x 1/2" NPTM Nozzle 1/4" NPTM ----- Pipe clamp 3/4", for Top Water Manifold (with screw fasteners 1/4"-20) ----- Hydraulic tube assembly: Hydraulic tubes 1/2" O.D.xW.035" stainless steel TP304/TP304L ASTM A269 Tube support sleeves 1/2" JIC Nuts 1/2" JIC ----- Hydraulic hose assembly: Hydraulic hose 3/8" I.D.x34"lg., thermoplastic Crimp fitting SAE 37° JIC swivel (female) Crimp fitting SAE 37° JIC male flare ----- Damping clamp 1/2", for hydraulic tubes (w/screw fasteners 1/4")	WC3L WA1LA WA1LAA SAE140109P-8 BRBPP050X050 NZ14 - SAE140438-8-8 BRBPP050X050 PPP3-4 WA1LA WA1LAA SAE140109P-8 BRBPP050X050 NZ14 PPP3-4 - - SAE070115-8 SAE070110-8 WA1LB SAE100R7-06x34 FC5810-0806 FC5807-0806 DMP12	- 4 4 4 4 16 4 12 20 4 4 4 4 16 8 - - 4 4 16 16 8 24 122



DUAL Z-WRAP w/DUAL MINI MITTER COMBO, Model 2WDM5



Figure 2

In order to get a higher application pressure at either driver side or passenger side of the machine, move the top bearings towards the center of the tunnel (toward the vehicle), or away from the center to achieve lower application pressure.

note: Application pressure is the pressure of the brush applied onto the car.

Fine tuning adjustment for getting better performance of AVW Wraps

- The RPM of the wrap hydraulic motor should be set at approximately 60 RPM to allow brush to flare out fully.
- Set hydraulic relief pressure so that brush can start to stall, when contacting the front end of the widest vehicle and then increase $\frac{1}{2}$ turn. The brush should never be able to stall on a front end of vehicle.
- Use a lot of soap and lubrication on the cloth.
- Do not use excessively worn cloth.
- Replace shock absorbers approximately every 6 months.
- Travel on back of car should not exceed $\frac{3}{4}$ of back end of vehicle.
- Keep initial adjustments light as wraps will tend to loosen up as they break in and cloth absorbs more soap and water.
- Start adjusting with bearings straight up and down, usually no more than $\frac{1}{4}$ " of bearing travel will be required
 - Set wraps for average conveyor speed, if conveyor speed increases or decreases more than 25 cars per hour up or down (50 cars per hour range) additional adjustment may be required.

Flex coupler fails or twists

Possible Causes & Troubleshooting:

- Torque settings on hydraulics is set too high.
- Flex coupler should be replaced approx. every 200,000 cars.



DUAL Z-WRAP w/DUAL MINI MITTER COMBO, Model 2WDM5

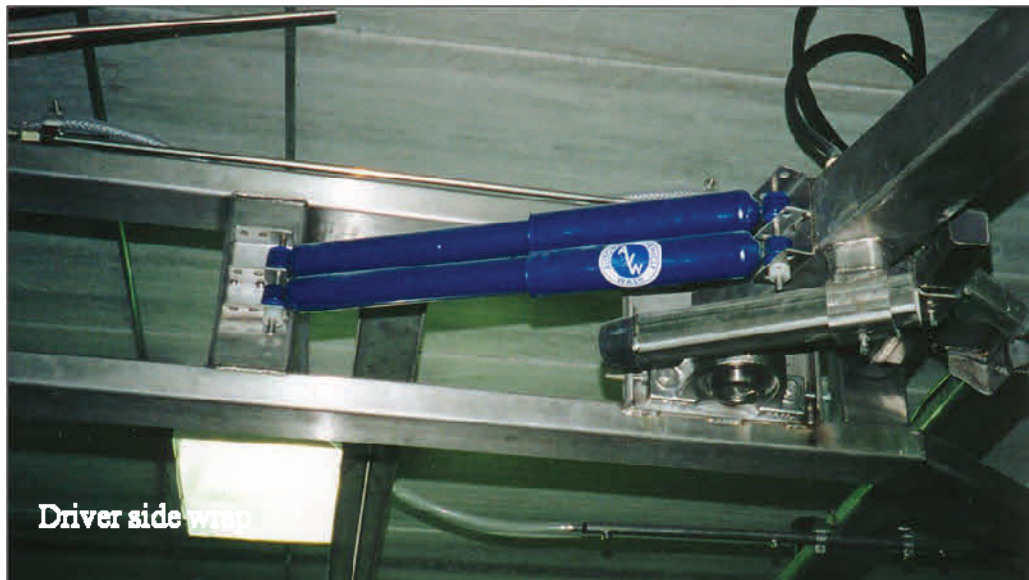

Figure 2

Brush climb up on back ends of the car

Possible Causes & Troubleshooting:

- The car is rolling ahead because of uneven floor and stopping with wrap on rear of car.
- Torque (Pressure) is set too high and brush will not stall as it climbs.
- Brush speed may be too fast. set at 60 RPM
- Brush may be set to travel more than 3/4 of backend of car / more swing after break- in period.
- Keep pivot point low as possible try not to mount over tire brushes or where high clearance is needed off the floor.
- Car may be stopping or rolling because of a treadle on floor or pocket in floor
- If the friction is too high-apply more soap or lubrication.
- The faster the brush RPM, the more travel on the back of the vehicle-adjust RPM.

Figure 3



Mirror is damaged or broken

Possible Causes & Troubleshooting:

- Lower portion of the brush is set to high coming into contact with mirror-stay below 33" from the top of the lower fuller section of the brush.
- Arm is restricted not to swing out far enough to clear the vehicle-adjust the bumper so that brush can clear the vehicle.
- Too much tilt on the bearing causing excessive side pressure –adjust the tilt on the bearing to reduce the pressure.
- Weak shocks absorbers-replace shock absorbers.
- Brush speed incorrect-set the speed.

