

ROLLER CORRELATOR, MODEL RC4

The AVW Roller Correlator is constructed of high grade Stainless Steel and durable UHMW. It's simple design fits most existing frames. No screws, bolts, springs, pins, or grease fittings. Roller lift out for easy replacement and cleaning.

Can also be customized to fit odd sizes.

- *Aligns Tire To Conveyor*
- *Stainless Steel Rollers and Shafts*
- *Roller lift out*
- *Maintenance Free*
- *No Spring or Pins*
- *No Greasing*
- *Low Friction UHMW*
- *No Metal To Metal Rolling Contact*
- *Stainless Steel Frame*

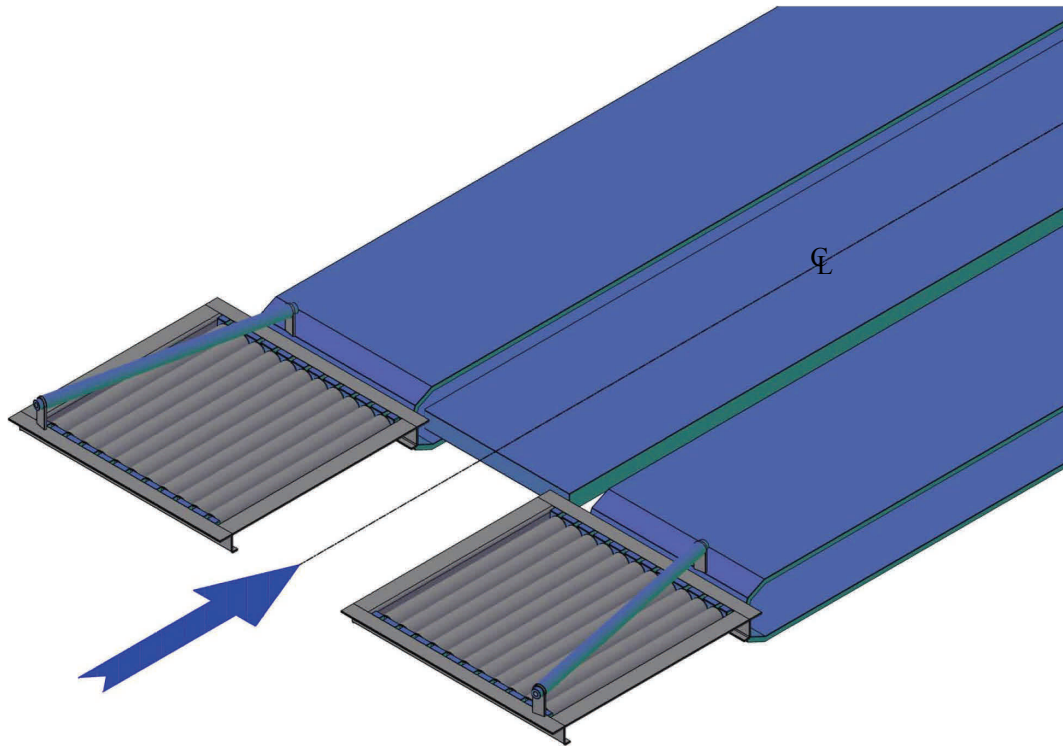

ROLLER CORRELATOR, MODEL RC4

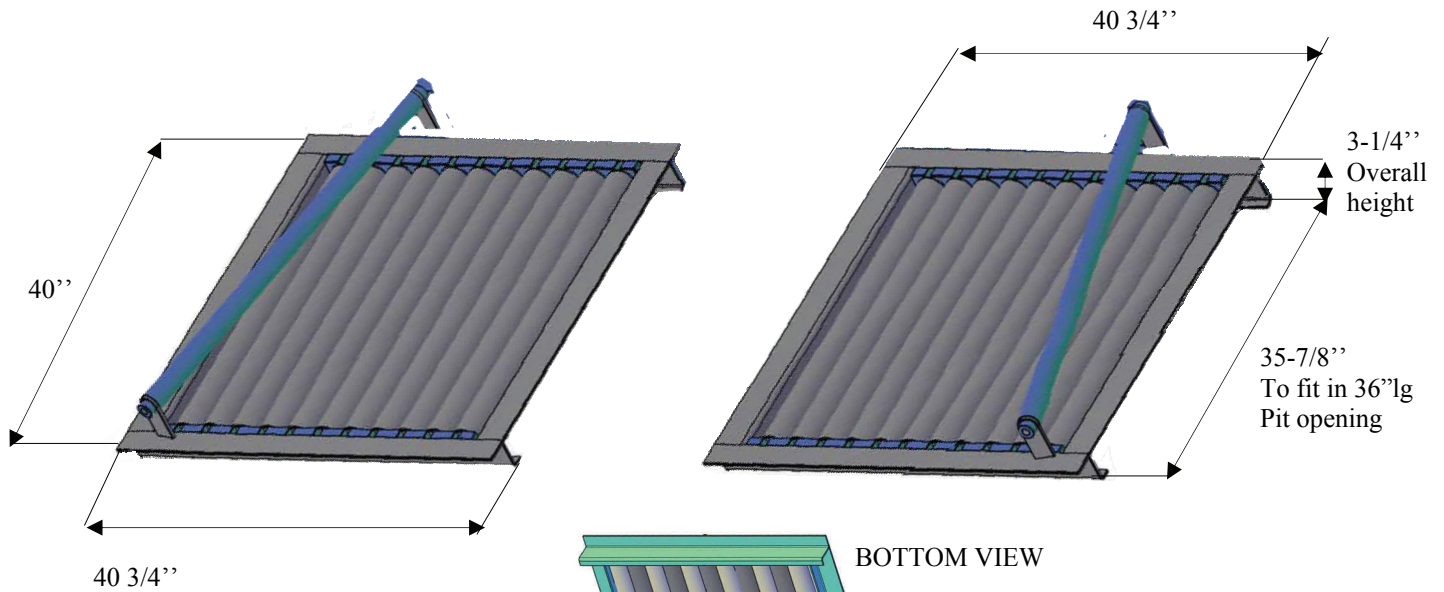
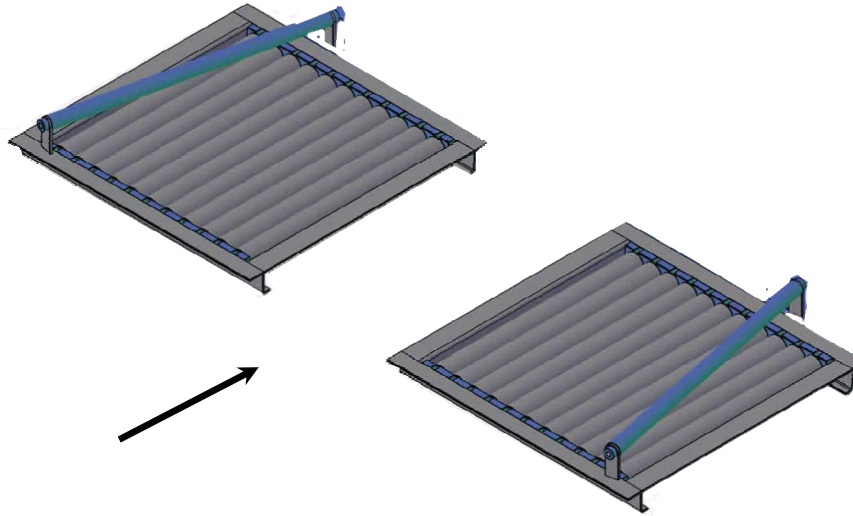

FRONT VIEW



BOTTOM VIEW

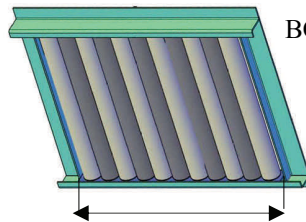

34-1/2"
To fit in
34-5/8" wide
open opening

SIDE VIEW

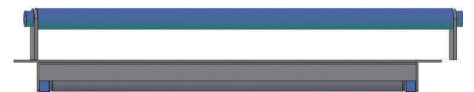

ROLLER CORRELATOR, MODEL RC4

1. GUIDE RAIL ASSEMBLY

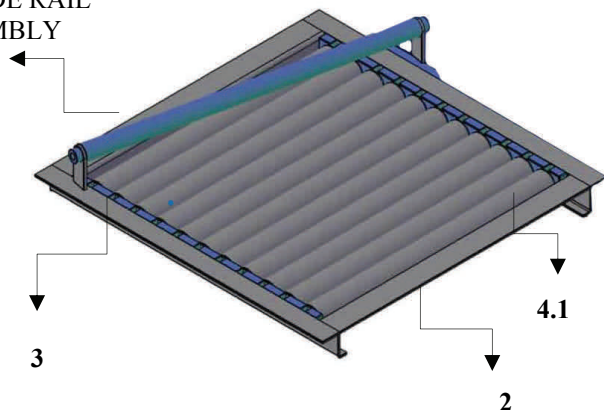

2. FRAME

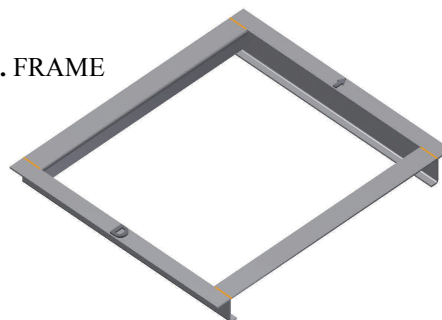

3. ROLLER SEAT



4. ROLLER ASSEMBLY

4.1 ROLLER



4.2 UHMW BUSHING



4.3 ROLLER SHAFT



1. GUIDE RAIL ASSEMBLY

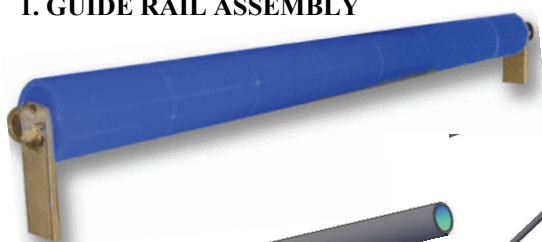

a. HOLDER (BRACKET w/COLLAR)

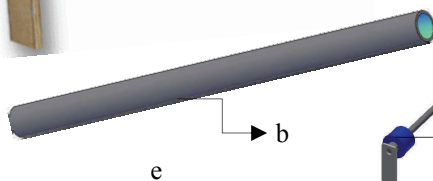

D. SHAFT

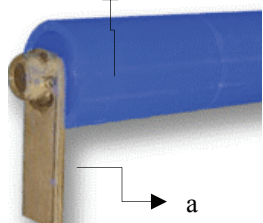

ITEM	Description	PART No.	Qty.
1	GUIDE RAIL ASSEMBLY	RC3DG	2
a	HOLDER (BRACKET w/COLLAR)	RC1DGH	4
b	ROLLER	RC3DG1	2
c	UHMW BUSHING 3/4" I.D.x2-3/4"O.D.	RC3DG2	4
d	SHAFT 3/4" x 42" LG	RC1DG3	4
e	UHMW ROLLER	RC3DG-UHMW1	8 per Rail

ITEM	Description	DRIVER SIDE " RC3D"	
		PART No.	Qty
2	FRAME	RC3DA	1
3	ROLLER SEAT	RC3DB	2
4	ROLLER ASSEMBLY	RC3DC	11
4.1	ROLLER	RC3DC1	11
4.2	UHMW BUSHING	RC3DC2	22
4.3	ROLLER SHAFT	RC1DC3	11



ROLLER CORRELATOR, MODEL RC4

CONCRETE FOR ROLLER CORRELATOR

