

CONTOUR BRUSH AVW Style, Model CB0405

The AVW Free Standing Contour Brush is constructed of heavy grade Stainless Steel. Designed to thoroughly clean the sides of vehicles through the use contouring adjustment. Van High brush height is ideal for vans and sport utility vehicles because it cleans the sides with smooth even pressure.

Hydraulic motors:

*For contour brushes:
displacement 5.0 cu. in./rev.
(= 1.3GPM at 60RPM)
(RPM is adjustable)*

Water:

*½" NPT Outlet
Equipment Center Line
28" from inside Conveyor Rail*

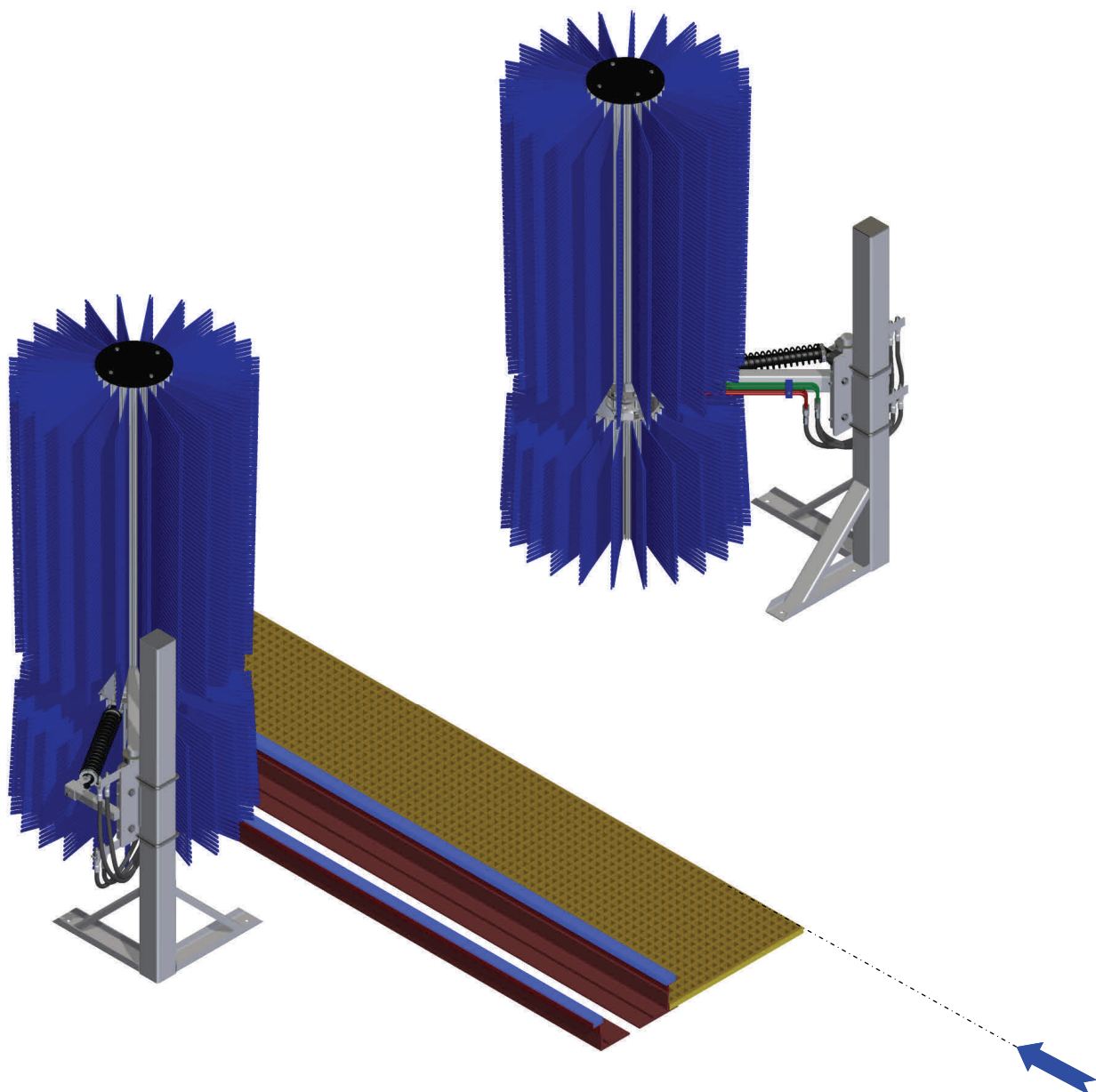

CONTOUR BRUSH AVW Style, Model CB0405

SPACE REQUIREMENT

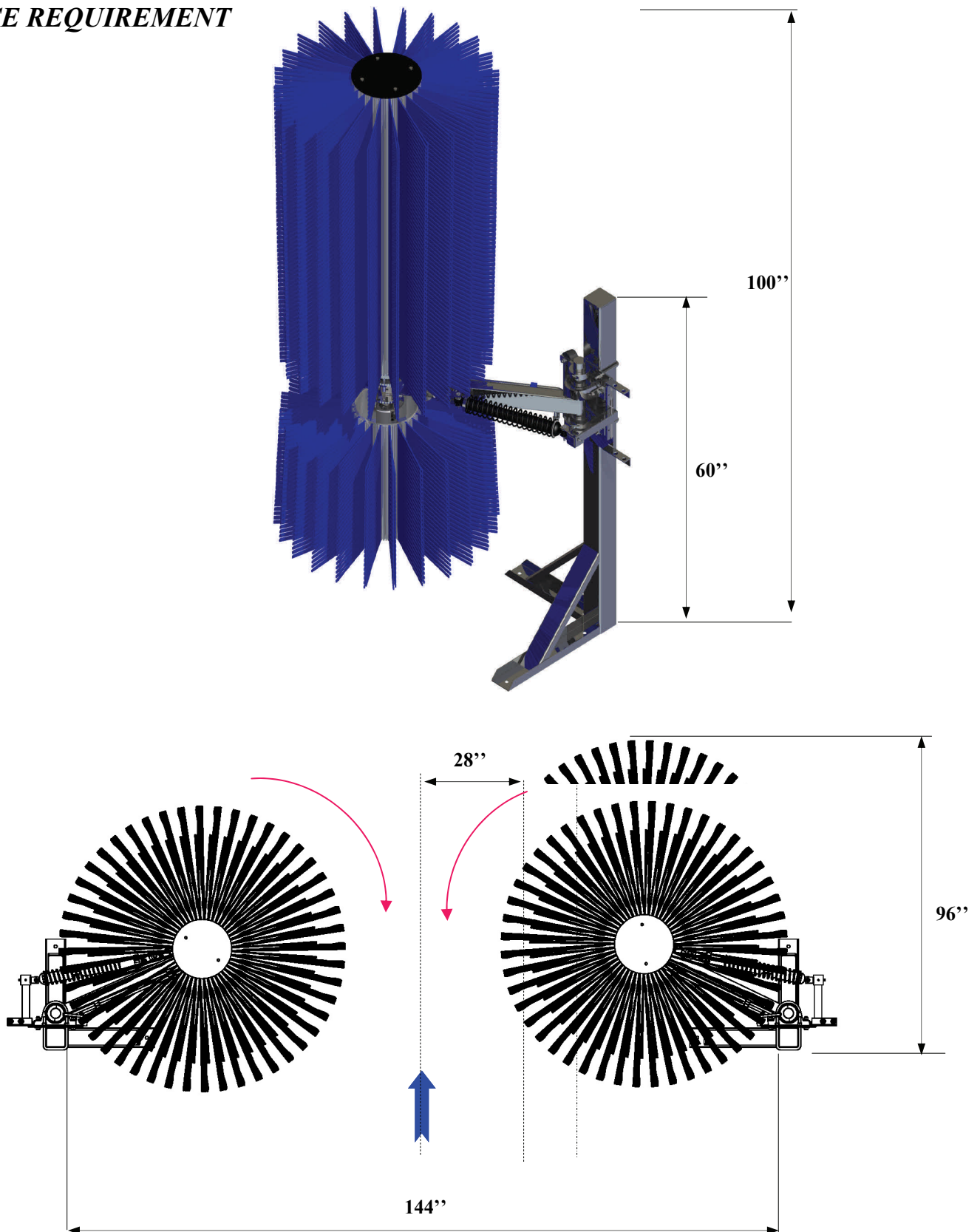

CONTOUR BRUSH AVW Style, Model CB0405

PARTS:

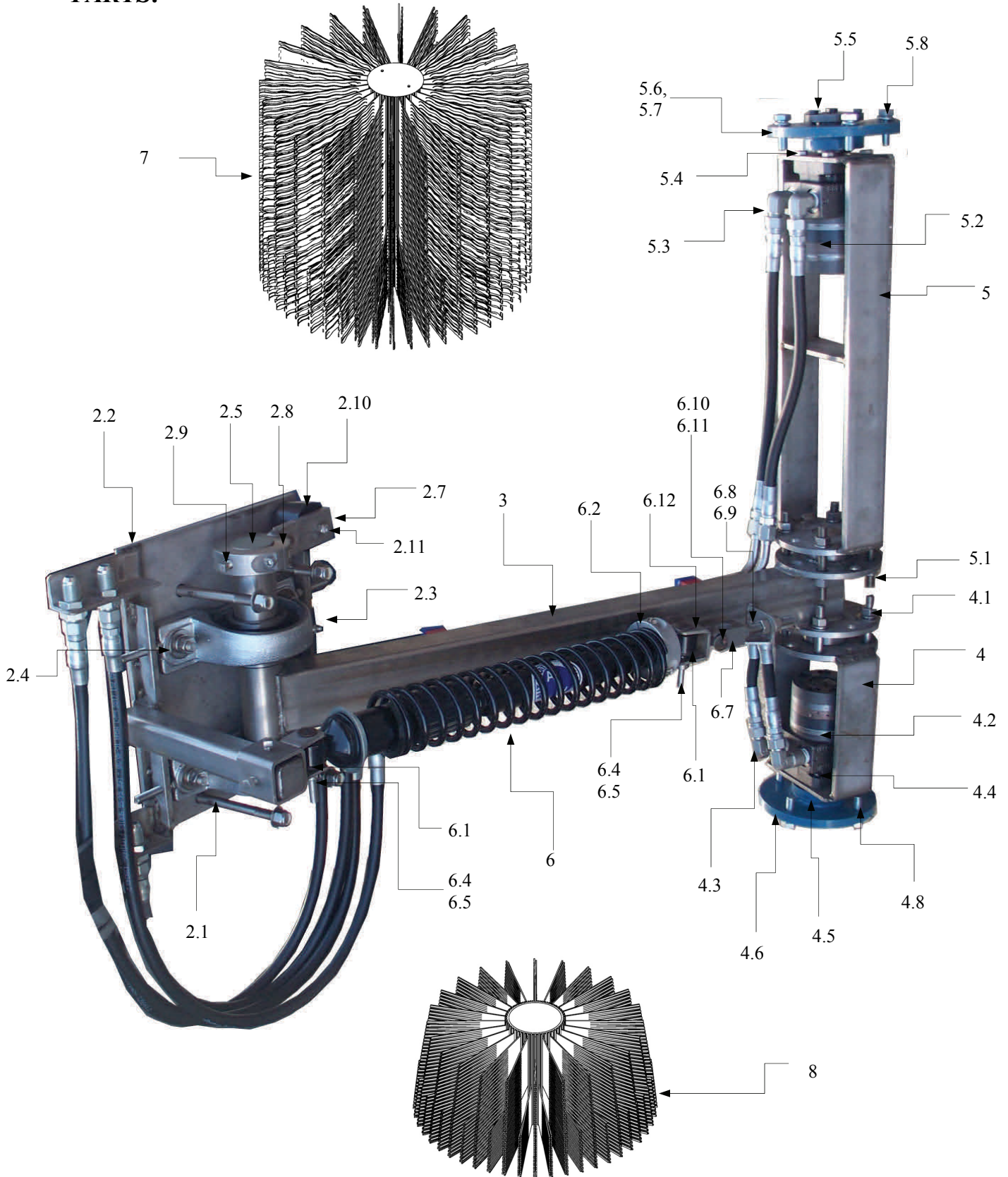

CONTOUR BRUSH AVW Style, Model CB0405

HYDRAULIC TUBE INSTALLATION and HYDRAULIC HOSE INSTALLATION

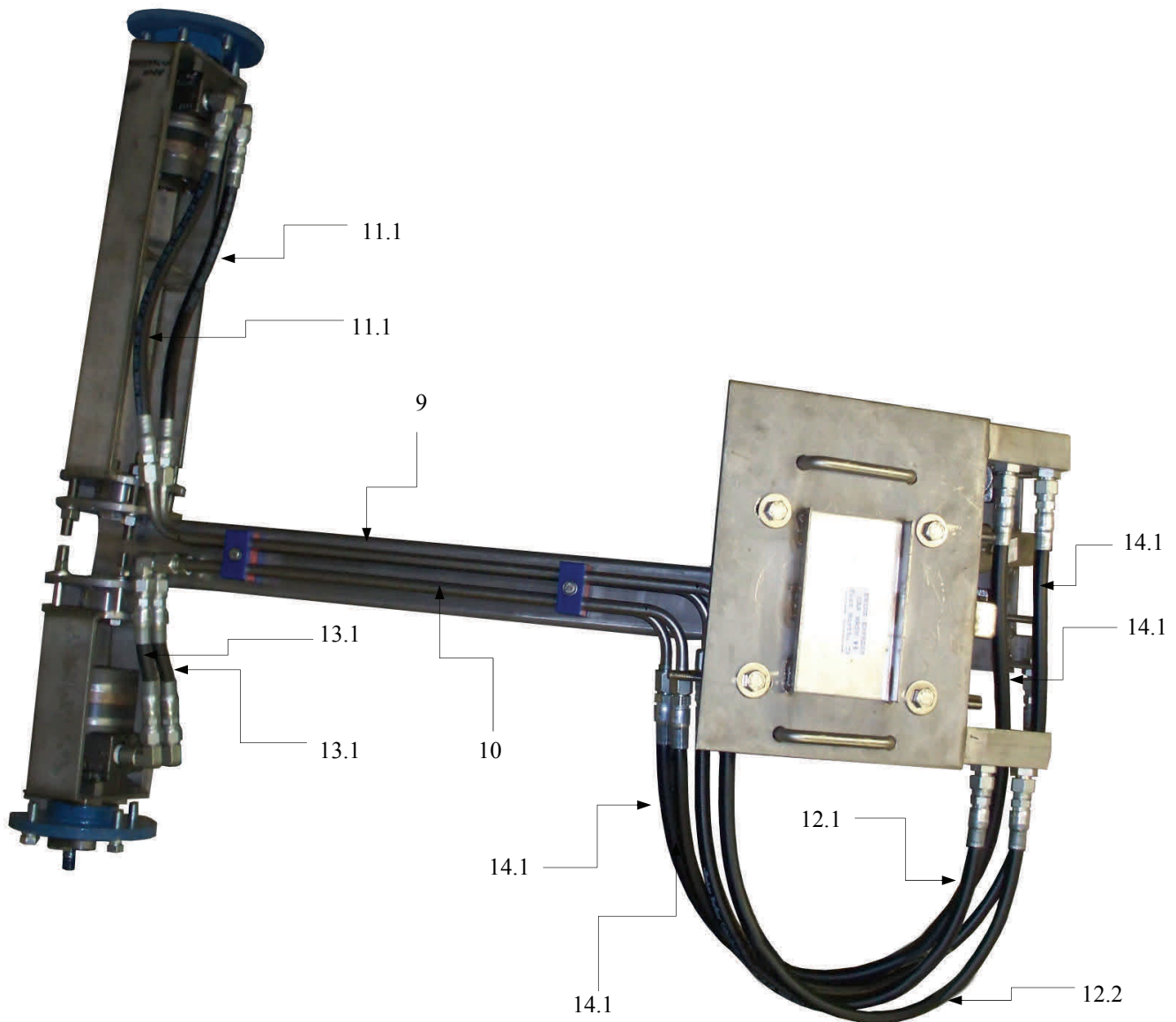

CONTOUR BRUSH AVW Style, Model CB0405

ITEM	Description	DRIVER SIDE		PASSENGER SIDE	
		PART NO.	Qty	PART NO.	Qty
-	CONTOUR BRUSH SIDE CONTOUR BRUSH SIDE w/o LEG	CB0405A CB0405YA	1 1	CB0405B CB0405YB	1 1
1	LEG	CB0405AA	1	CB0405AA	1
-	ARM ASSEMBLY (w/o Leg, w/o Brush)	CB0405D	1	CB0405E	1
2	ARM MOUNT ASSEMBLY	CB0405AB	1	CB0405BB	1
2.1	Square U-Bolt Fastener set 1/2"	RB2ABB	2	RB2ABB	2
	Square U-Bolt 1/2"x17"lg	RB2ABB1	2	RB2ABB1	2
	Split lock Washer 1/2"	SLW12	2	SLW12	2
	Hex Nut 1/2"-13	HN1213	2	HN1213	2
2.2	ARM MOUNT	CB0405ABA	1	CB0405ABA	1
2.3	PILLOW BLOCK 2"	WA1WB	2	WA1WB	2
2.4	w/Screw Fastener Set (For Pillow Block)	-	2	-	2
	Hex Head Cap Screw 1/2"-13x2 1/2"lg	HHCS1213225	2	HHCS1213225	2
	Flat Washer 1/2" I.D.x1 1/4"O.D.	FW12125	2	FW12125	2
	Split Lock Washer 1/2"	SLW12	2	SLW12	2
	Hex Nut 1/2"-13	HN1213	2	HN1213	2
2.5	SHAFT 2" x 14-1/4"lg	CB0405SH	1	CB0405SH	1
2.6	BUMPER ASSEMBLY	CB0405AC	1	CB0405AC	1
2.7	BUMPER MOUNT	CB0405ACA	1	CB0405ACA	1
2.8	2-Piece COLLAR 2"				
2.9	Screw Fastener Set for Bumper:	-	1	-	1
	Hex Head Cap Screw 3/8"-16x1-1/2"lg	HHCS3816150	2	HHCS3816150	2
	Split Lock Washer 3/8"	SLW38	2	SLW38	2
	Hex Nut 3/8"-16	HN3816	1	HN3816	1
2.10	RUBBER STOP (BUMPER)	WA1DBB	1	WA1DBB	1
2.11	Screw Fastener Set 3/8" (for bumper):	-	1	-	1
	Hex Head Cap Screw 3/8"-16x1 1/4"lg.	HHCS3816125	1	HHCS3816125	1
	Flat Washer 3/8"x7/8"O.D.	FW38087	1	FW38087	1
	Hex Nut 3/8"-16	HN3816	1	HN3816	1
3	ARM (Weldment assembly only)	CB0405EAx32	1	CB0405DAx32	1



CONTOUR BRUSH AVW Style, Model CB0405

ITEM	Description	DRIVER SIDE		PASSENGER SIDE	
		PART NO.	Qty	PART NO.	Qty
-	BRUSH DRIVE LOWER ASSEMBLY	RB1AE	1	RB1AE	1
4	MOTOR MOUNT (8" LG)	RB1AEA	1	RB1AEA	1
4.1	Screw Fastener Set ½" (connection of the motor mount with the arm):	-	4	-	4
	Hex Head Cap Screw ½" -13x3"LG.	HHCS1213300	4	HHCS1213300	4
	Flat Washer ½" I.D.x1¼"O.D.	FW12125	4	FW12125	4
	Split Lock Washer ½"	SLW12	4	SLW12	4
	Hex Nut ½"-13	HN1213	4	HN1213	4
4.2	HYDRAULIC MOTOR , [displacement 5.0cu.in./rev.]	TB1ADBМ	1	TB1ADBМ	1
4.3	- Fitting 90°Elbow ½" NPTM x ½" JIC	SAE070202-8-8	2	SAE070202-8-8	2
4.4	- Hex Head Cap Screw 3/8"-16x ¾" lg. (connection of the motor with the motor mount)	HHCS3816075	4	HHCS3816075	4
4.5	SPLIT TAPER BUSHING 1" (set w/two socket set screws ¼"-20x ½"lg., carbon steel)	STB-P1X100	1	STB-P1X100	1
		SSS1420050C	2	SSS1420050C	2
4.6	BRUSH CONNECTING DISK	RB2AEB-P1-1-0106	1	RB2AEB-P1-1-0106	1
4.7	w/welded weld-on hub	MC2BBA3-P1-1-01061	1	MC2BBA3-P1-1-01061	1
4.8	Screw Fastener Set ½" (connection of the brush with disk):	-	4	-	4
	Hex Head Cap Screw ½" -13x1¼" LG.	HHCS1213125	4	HHCS1213125	4
	Split Lock Washer ½"	SLW12	4	SLW12	4
	Hex Nut ½"-13	HN1213	4	HN1213	4
-	BRUSH DRIVE UPPER ASSEMBLY	RB2AE	1	RB2AE	1
5	MOTOR MOUNT (20" LGF)	RB2AEA	1	RB2AEA	1
5.1	Screw Fastener Set ½" (connection of the motor mount with the arm):	-	4	-	4
	Hex Head Cap Screw ½" -13x3"lg.	HHCS1213300	4	HHCS1213300	4
	Flat Washer ½" I.D.x1¼"O.D.	FW12125	4	FW12125	4
	Split Lock Washer ½"	SLW12	4	SLW12	4
	Hex Nut ½"-13	HN1213	4	HN1213	4
5.2	HYDRAULIC MOTOR , displacement 5.0 [cu.in./rev.]	TB1ADBМ	1	TB1ADBМ	1
5.3	- Fitting 90°Elbow ½" NPTM x ½" JIC	SAE070202-8-8	2	SAE070202-8-8	2
5.4	- Hex Head Cap Screw 3/8"-16x ¾" lg. (connection of the motor with the motor mount)	HHCS3816075	4	HHCS3816075	4
5.5	SPLIT TAPER BUSHING 1" (set w/two socket set screws ¼"-20x ½"lg., carbon steel)	STB-P1X100	1	STB-P1X100	1
		SSS1420050C	2	SSS1420050C	2
5.6	BRUSH CONNECTING DISK	RB2AEB-P1-1-0106	1	RB2AEB-P1-1-0106	1
5.7	w/welded weld-on hub	MC2BBA3-P1-1-01061	1	MC2BBA3-P1-1-01061	1
5.8	Screw Fasteners (connection of the brush with disk):	-	4	-	4
	Hex Head Cap Screw ½" -13x1¼" LG.	HHCS1213125	4	HHCS1213125	4
	Split Lock Washer ½"	SLW12	4	SLW12	4
	Hex Nut ½"-13	HN1213	4	HN1213	4



CONTOUR BRUSH AVW Style, Model CB0405

ITEM	Description	DRIVER SIDE		PASSENGER SIDE	
		PART NO.	Qty	PART NO.	Qty
-	SHOCK ABSORBER ASSEMBLY:	RB1AF	1	RB1AF	1
6	SPRING SHOCK ABSORBER	RB1AFA	1	RB1AFA	1
6.1	UHMW Bushing 3/8" I.D.	RB1AFA1	2	RB1AFA1	2
6.2	Spring Adjuster Assembly (aluminum 2-piece collar):	RB2AFB	1	RB2AFB	1
	-Aluminum Adjuster (2-piece collar)	RB2AFB1	1	RB2AFB1	1
	-Hex Head Cap Screw 1/4" -20 x 1 1/4" lg.	HHCS1420125	2	HHCS1420125	2
	-Hex Nut 1/4" -20	HN1420	2	HN1420	2
6.3	Plastic Spacer	RB1AFC	1	RB1AFC	1
6.4	PIN Ø3/8"x3"lg.	TB1AEA	2	TB1AEA	2
6.5	COLLAR 3/8"	WA1FC	2	WA1FC	2
6.6	FRONT MOUNT:	RB1AG	1	RB1AG	1
6.7	-Clevis	WA2GA1	1	WA2GA1	1
6.8	-Threaded Rod 1/2" -13x5"lg.	WA2GA2	1	WA2GA2	1
6.9	-Hex Nut 1/2"-13	HN1213	3	HN1213	3
6.10	-Pin 3/8"x1 1/2"lg.	WA1GB	1	WA1GB	1
6.11	-Collar 3/8"	WA1FC	1	WA1FC	1
6.12	-Shock Mount	RB1AGA	1	RB1AGA	1
7	UPPER BRUSH 51" ASSEMBLY:	CB0405AM-51	1	CB0405AM-51	1
7.1	Brush Cloth	CB1AMA-51	1	CB1AMA-51	1
7.2	Aluminum Extrusion	CB1AMC-51	2	CB1AMC-51	2
7.3	Two-piece Collar 1 1/2"x12 core	CB1AMB-51	2	CB1AMB-51	2
7.4	Screw Fastener Set 3/8", for collar	-	8	-	8
8	LOWER BRUSH 21" ASSEMBLY:	CB0405AM-21 (28")	1	CB0405AM-21 (28")	1
8.1	Brush Cloth		1		1
8.2	Aluminum Extrusion	CB1AMA-21(28)	2	CB1AMA-21(28)	2
8.3	Two-piece Collar 1 1/2"x12 core	CB1AMC-21(28)	2	CB1AMC-21(28)	2
8.4	Screw Fastener Set 3/8", for collar	CB1AMB-21(28)	8	CB1AMB-21(28)	8
		-		-	



CONTOUR BRUSH AVW Style, Model CB0405

ITEM	Description	DRIVER SIDE		PASSENGER SIDE	
		PART NO.	Qty	PART NO.	Qty
-	HYDRAULIC TUBE INSTALLATION,STAINLESS STEEL :	CB0405LD	1	CB0405LP	1
9	HYDRAULIC TUBE ASSEMBLY (UPPER):	CB0405LDA	2	CB0405LDA	2
9.1	Hydraulic Tube ½”O.D.xW.035”X28”LG (LINE IN)	CB0405LDA1x28	1	CB0405LDA1x28	1
	Hydraulic Tube ½”O.D.xW.035”X29”LG (LINE OUT)	CB0405LDA1x29	1	CB0405LDA1x29	1
9.2	Tube support Sleeve ½”JIC	SAE070115-8	4	SAE070115-8	4
9.3	Nut ½”JIC	SAE070110-8	4	SAE070110-8	4
9.4	Fitting 90°elbow ½” JIC x ½”JIC	SAE070201-8-8	2	SAE070201-8-8	2
10	HYDRAULIC TUBE ASSEMBLY (LOWER):	CB0405LDA	2	CB0405LDA	2
10.1	Hydraulic Tube ½”O.D.xW.035”X24”LG (LINE IN)	CB0405LDA1x24	1	CB0405LDA1x24	1
	Hydraulic Tube ½”O.D.xW.035”X25”LG (LINE OUT)	CB0405LDA1x25	1	CB0405LDA1x25	1
10.2	Tube Support Sleeve ½”JIC	SAE070115-8	4	SAE070115-8	4
10.3	Nut ½”JIC	SAE070110-8	4	SAE070110-8	4
10.4	Fitting 90°elbow ½” JIC x ½”JIC	SAE070201-8-8	2	SAE070201-8-8	2
-	HYDRAULIC HOSE INSTALLATION :	CB0405HD	1	CB0405HD	1
11	HYDRAULIC HOSE ASSEMBLY (UPPER BRUSH):	CB0405HDA	2	CB0405HDA	2
11.1	Hydraulic Hose 3/8”I.D x 15”lg, thermoplastic	SAE100R7-06x15	2	SAE100R7-06x15	2
11.2	Crimp Fitting SAE 37° JIC Swivel (female)	FC5810-0806	4	FC5810-0806	4
12	HYDRAULIC HOSE SET:	CB0405LDDx27	2	CB0405LDDx27	2
12.1	Hydraulic Hose 3/8”I.D x 27”lg, thermoplastic	SAE100R7-06x27	2	SAE100R7-06x27	2
12.2	Crimp Fitting SAE 37° JIC Swivel (female)	FC5810-0806	2	FC5810-0806	2
12.3	Crimp Fitting SAE 37° JIC male flare	FC5807-0806	2	FC5807-0806	2
12.4					
12.5	Fitting– straight bulkhead 1/2”JIC x 1/2”JIC, Brass	SAE 700601	2	SAE 700601	2
13	HYDRAULIC HOSE ASSEMBLY (LOWER BRUSH):	CB00405HDB	2	CB0405HDB	2
13.1	Hydraulic Hose 3/8”I.D x 5”lg, thermoplastic	SAE100R7-06x5	2	SAE100R7-06x5	2
13.2	Crimp Fitting SAE 37° JIC Swivel (female)	FC5810-0806	4	FC5810-0806	2
14	HYDRAULIC HOSE SET:	CB0405LDDx36	2	CB0405LDDx36	2
14.1	Hydraulic Hose 3/8”I.D x 36”lg, thermoplastic	SAE100R7-06x36	2	SAE100R7-06x36	2
14.2	Crimp Fitting SAE 37° JIC Swivel (female)	FC5810-0806	2	FC5810-0806	2
14.3	Crimp Fitting SAE 37° JIC male flare	FC5807-0806	2	FC5807-0806	2
14.4	Fitting– straight bulkhead 1/2”JIC x 1/2”JIC, Brass	SAE 700601-8-8	2	SAE 700601-8-8	2

